

正鶴工業股份有限公司

Standard Motor Corporation

SK3

SPARE PARTS
LIST

10 FL 65 SUNG CHIANG RD, TAIPEI TAIWAN

TEL:886-2-25066277 FAX:886-2-25071915

序 言

本零件手冊僅適用於本公司 SK3系列的機種,當您要訂購此機種之零件時,請參考這本手冊,並正確的引用零件號碼和零件名稱。

- 一、在本零件手冊發行後,若有修改、增訂或價格調整時,將會另行通知,當您接到變更通知時,請您務必按照變更通知更正您手中的零件手冊,以隨時保持準確度。
- 二、顏色與型式會隨著運用逐漸增加,增加之顏色、型式僅列舉在"差異表"內,當您要訂購這些零件時,請參考零件手冊中之零件號碼和零件名稱並參考"差異表"選擇您所需要的顏色、型式後,寫出正確完整的零件號碼與零件名稱並加註備註欄內容。
- 三、細小之另件以本公司之最小販賣單位為購買單位(價格另以單位價計)
- 四、零件號碼

<A>一般零件組

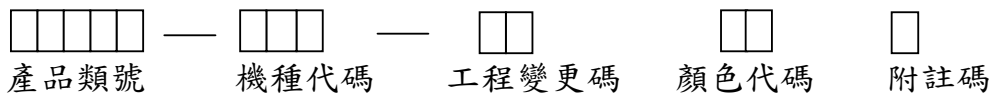

標準品

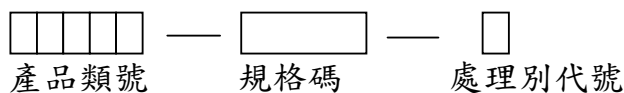

C O N T E N T

目 錄

- 一． CYLINDER 汽缸
- 二． CRANKSHAFT, PISTON 曲軸、活塞
- 三． AIR SHROUD, FAN 空氣進氣孔、風扇
- 四． OIL PUMP 潤滑油泵
- 五． CARBURETOR 化油器
- 六． INTAKE 空氣吸入口
- 七． CRANKCASE 曲軸箱
- 八． STARTER 起動機構
- 九． CLUTCH 離合器
- 十． TRANSMISSION 傳動機構
- 十一． GENERATOR 發電機
- 十二． STARTING MOTOR 起動馬達
- 十三． EXHAUST MUFFLER 排氣管
- 十四． REAR SUSPENSION 後懸吊系統
- 十五． REAR BRAKE 後剎車系統
- 十六． FRAME 車架
- 十七． STEERING 轉向裝置
- 十八． FRONT SUSPENSION 前懸吊系統
- 十九． FRONT WHEEL 前輪
- 二十． REAR WHEEL 後輪
- 二十一． FUEL TANK 油箱
- 二十二． STEERING KNUCKLE 轉向關節座
- 二十三． STEERING HANDLE CABLE 轉向把手,鋼索
- 二十四． FRONT FENDER, WARNING 前土除、警告標示
- 二十五． SEAT 座墊
- 二十六． HEADLIGHT 前燈
- 二十七． WIRE HARNESS 主電路配線
- 二十八． REMOTE CONTROL ENGINE STOP SWITCH 遙控器組
- 二十九． HANDLE SWITCH, LEVER 把手開關、拉桿

一、CYLINDER 汽缸

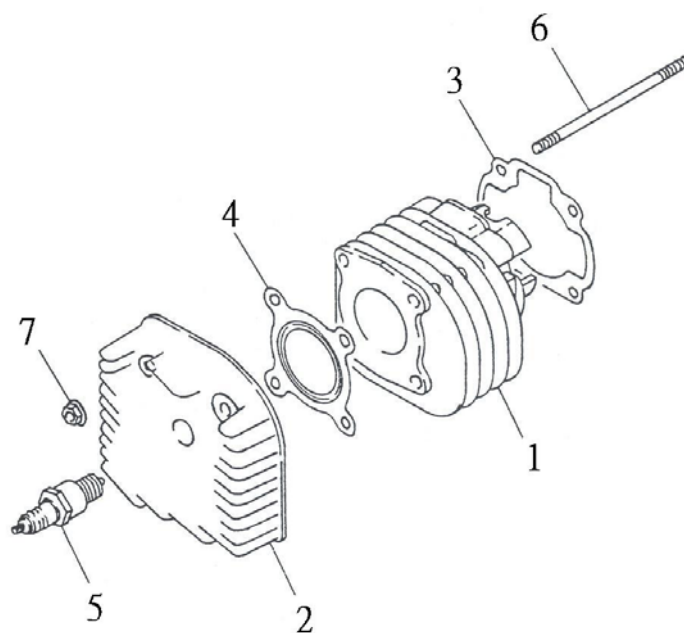

NO. 項目	PARTS NO. 零件號碼	PARTS NAME 零件名稱		Q'TY 用量	NOTE 備註
1	11111-SK2-00	CYLINDER	汽缸	1	
2	11121-NAF-00	HEAD, CYLINDER	汽缸蓋	1	
3	11151-NAF-00	GASKET, CYLINDER	汽缸墊片	1	
4	11181-NAF-00	GASKET, CYLINDER HEAD	汽缸蓋墊片	1	
5	62210-NAF-01	PLUG, SPARK (NGK BPR7HS)	火星塞總成	1	
6	94717-07109-C	BOLT, STUD	雙頭螺栓	4	
7	95401-071007-C	NUT, FLANGE	凸緣螺帽	4	

二、CRANKSHAFT, PISTON 曲軸、活塞

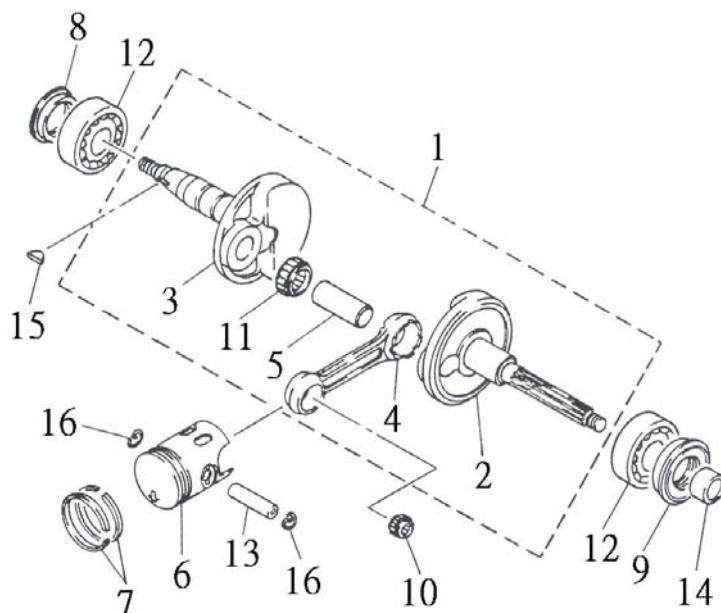

NO.	PARTS NO.	PARTS NAME		Q'TY	NOTE
項目	零件號碼	零件名稱		用量	備註
1	11400-SK5-00	CRANKSHAFT ASSEMBLY	曲軸總成	1	
2	11412-SK5-00	CRANK L	左曲軸	1	
3	11422-SK5-00	CRANK R	右曲軸	1	
4	11451-NAF-00	ROD, CONNECTING	連桿	1	
5	11481-NAF-00	PIN, CRANK	曲軸銷	1	
6	11631-NAF-00	PISTON (STD)	活塞	1	
7	11636-NAF-00	PISTON RING SET (STD)	活塞環組	1	
8	93110-20306	OIL SEAL	油封	1	
9	93110-20428	OIL SEAL	油封	1	
10	93310-1014125	NEEDLE BEARING	滾針軸承	1	
11	93310-1622118	NEEDLE BEARING	滾針軸承	1	
12	93320-204714J3	BALL BEARING 6204JR2C3	滾珠軸承	2	
13	93510-051033	PIN, PISTON	活塞銷	1	
14	93510-152012	COLLAR	左曲軸隔環	1	
15	94420-03013	KEY, SEMICIRCLE	半圓鍵	1	
16	97050-10012	CIRCLIP	活塞銷止動環	2	

三、AIR SHROUD, FAN 空氣進氣孔、風扇

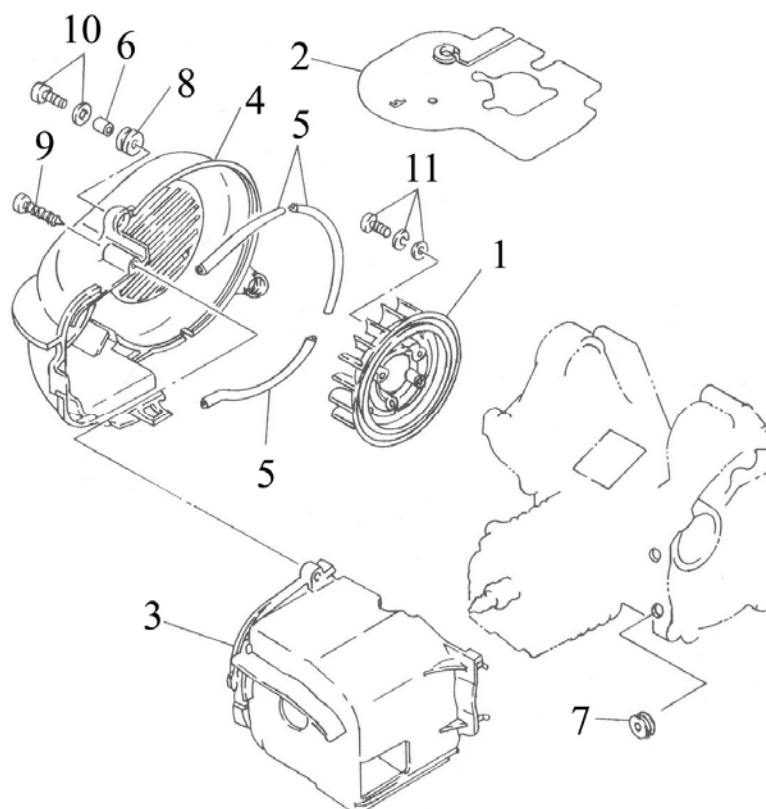

NO.	PARTS NO.	PARTS NAME	Q'TY	NOTE
項目	零件號碼	零件名稱	用量	備註
1	12611-NAF-00	FAN	1	風扇
2	12631-NAF-00	DEFLECTOR	1	轉折板
3	12651-NAF-00	AIR SHROUD, CYLINDER	1	汽缸護罩
4	12653-NAF-00	AIR SHROUD, FAN	1	風扇護蓋
5	12658-NAF-00	DAMPER, AIR SHROUD	3	風扇護蓋防震墊
6	93560-68510	COLLAR	2	軸環
7	93580-41810	GROMMET	2	汽缸護罩套環
8	93580-81610	GROMMET	2	套環
9	96110-64016-C	SCREW, TAPPING	1	自攻螺絲
10	96312-06020-K	SCREW, PAN HEAD WITH WASHER	2	十字孔頭螺絲附墊圈
11	96314-06016-C	SCREW, PAN HEAD WITH WASHER	4	十字孔頭螺絲附墊圈

四、OIL PUMP 潤滑油泵

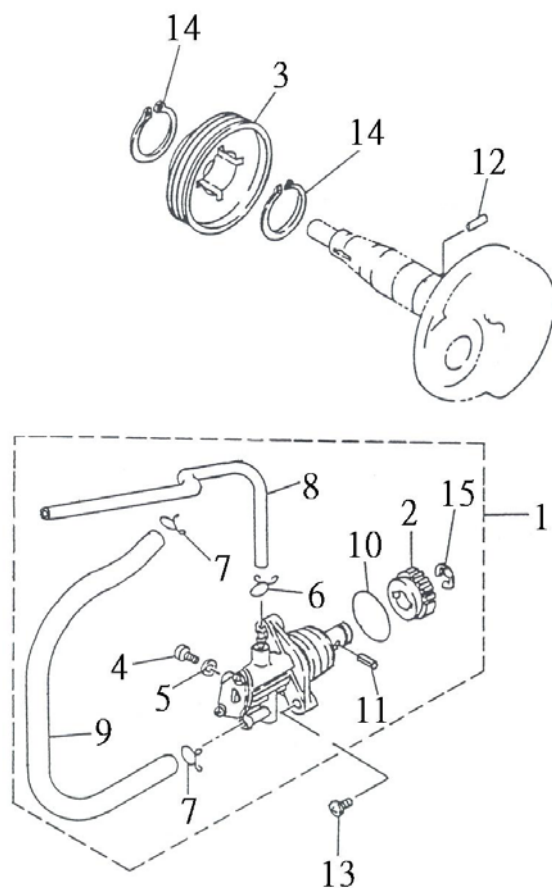

NO. 項目	PARTS NO. 零件號碼	PARTS NAME 零件名稱		Q'TY 用量	NOTE 備註
1	13100-SK2-00	OIL PUMP ASSEMBLY	潤滑油泵總成	1	
2	13124-NAF-00	GEAR WORM WHEEL (40T)	蝸輪	1	
3	13178-NAF-00	GEAR, PUMP DRIVE	驅動齒輪	1	
4	13185-NAF-00	BOLT, BREATHER	螺栓	1	
5	13187-NAF-00	GASKET, BREATHER BOLT	墊圈	1	
6	90210-06005-C	CLIP	管夾	1	
7	90210-08009-C	CLIP	管夾	2	
8	90310-20050	HOSE	耐油管	1	
9	90310-50510	HOSE	耐油管	1	
10	93210-16195	O-RING	護油圈	1	
11	94430-30012	PIN, DOWEL	彈簧銷	1	
12	94510-30012	PIN, POWEL	滾針	1	
13	96310-05014-C	SCREW, PAN HEAD	十字孔頭螺絲	2	
14	97010-19012	CIRCLIP	C形扣環	2	
15	97011-07008-K	CIRCLIP	E形扣環	1	

五、CARBURETOR 化油器

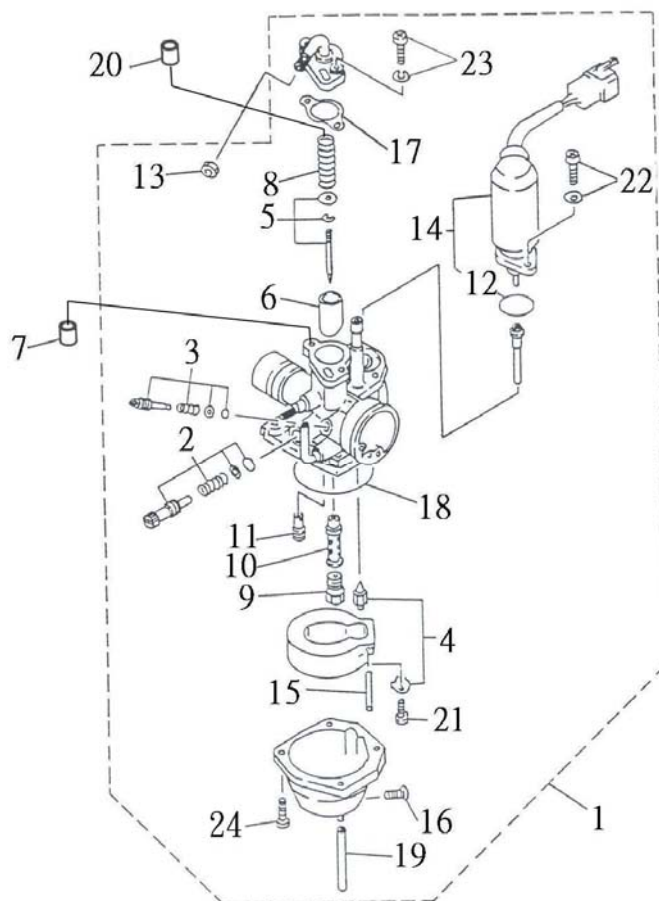

NO.	PARTS NO.	PARTS NAME	Q'TY	NOTE
項目	零件號碼	零件名稱	用量	備註
1	13201-NAF-01	CARBURETOR ASSEMBLY	1	化油器總成
2	13203-NAF-00	THROTTLE SCREW SET	1	節流調整螺絲組
3	13204-NAF-00	AIR SCREW SET	1	空氣螺絲組
4	13207-NAF-00	NEEDLE VALVE SET	1	油門座油針組
5	13211-NAF-00	NEEDLE SET	1	油針組
6	13212-NAF-00	VALVE, THROTTLE	1	節流閥
7	13223-NAF-00	PLUG, VALUUM	1	負壓管塞
8	13233-NAF-00	SPRING, THROTTLE STOP	1	節流閥彈簧
9	13240-NAF-01	JET, MAIN (#55)	1	主噴口
10	13241-NAF-00	NOZZLE, MAIN	1	主噴嘴
11	13242-NCF-00	JET, PILOT (#20)	1	引導噴口
12	13247-NAF-00	O-RING	1	護油圈
13	13261-NAF-00	NUT, CABLE ADJUSTING	1	螺帽
14	13271-NAF-00	PLUNGER, STARTER	1	起動阻塞總成
15	13286-NAF-00	PIN, FLOAT	1	浮筒銷
16	13291-NAF-00	PLUG, DRAIN	1	排洩口塞
17	13296-NAF-00	GASKET	1	墊片
18	13297-NAF-00	SEAL	1	封圈
19	13298-NAF-00	PIPE	1	管
20	93510-111411	COLLAR (11mm)	1	化油器銅隔環
21	96310-03006-C	SCREW, PAN HEAD	1	十字孔頭螺絲
22	96312-04008-C	SCREW, PAN HEAD WITH WASHER	2	十字孔頭螺絲附墊圈

五、CARBURETOR 化油器

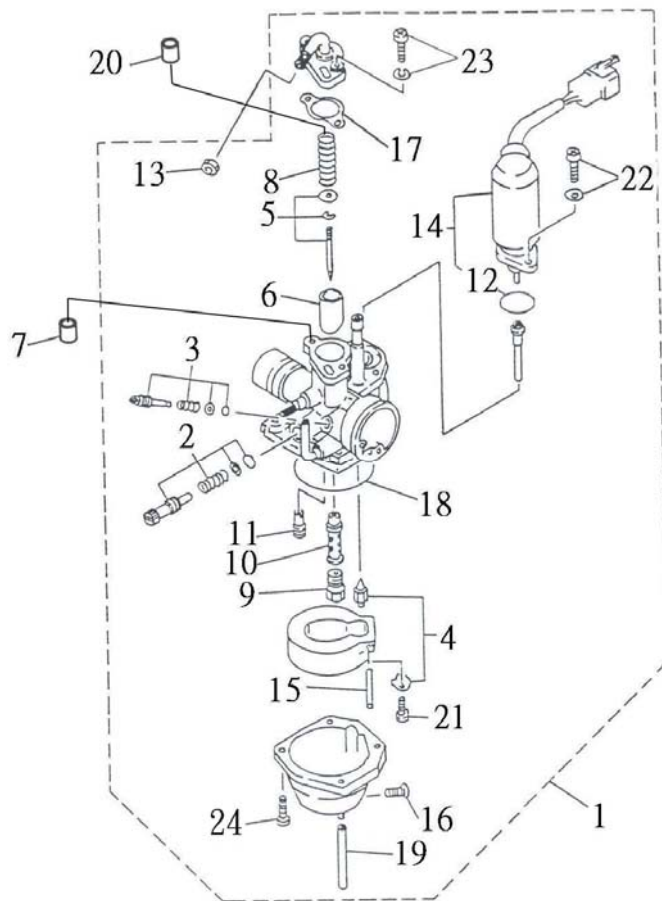

NO.	PARTS NO.	PARTS NAME	Q'TY	NOTE
項目	零件號碼	零件名稱	用量	備註
23	96312-04012-C	SCREW, PAN HEAD WITH WASHER	2	十字孔頭螺絲附墊圈
24	96312-04014-C	SCREW, PAN HEAD WITH WASHER	4	十字孔頭螺絲附墊圈

六、INTAKE 空氣吸入口

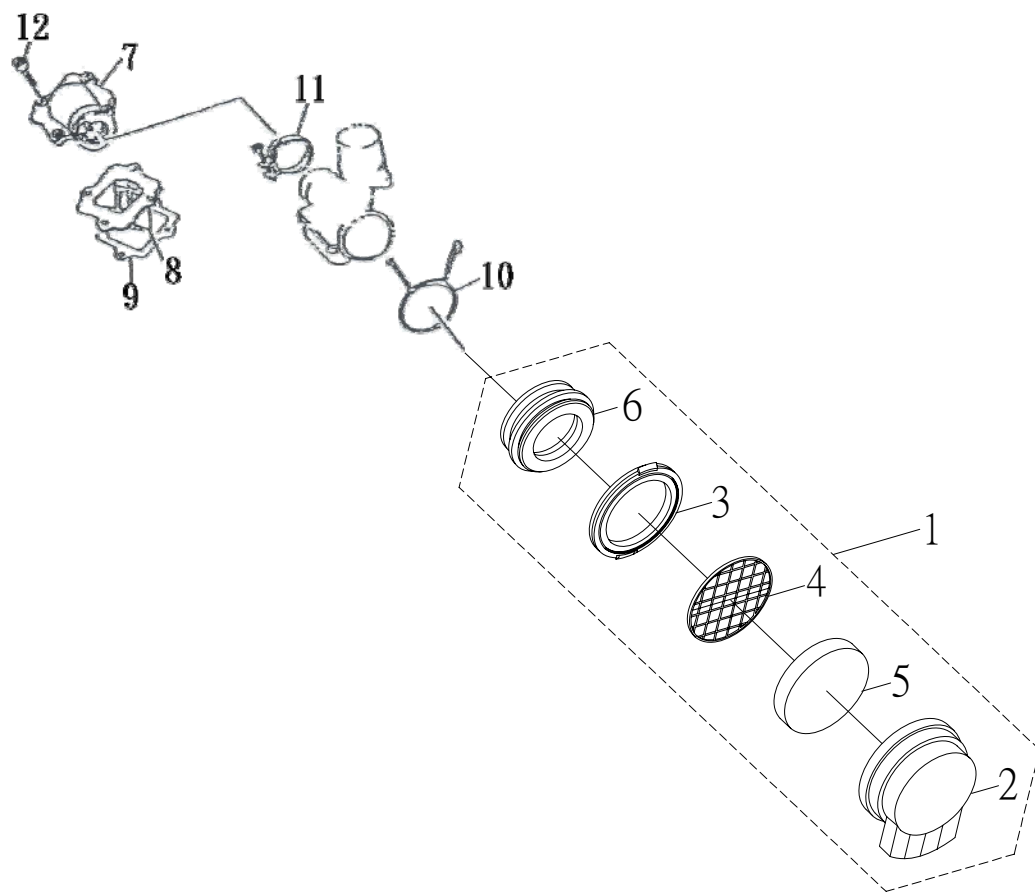

NO.	PARTS NO.	PARTS NAME		Q'TY	NOTE
項目	零件號碼	零件名稱		用量	備註
1	13410-SK3-00	AIR CLEANER ASSEMBLY	空氣濾清器總成	1	
2	13411-SK3-00	CASE, AIR CLEANER	空氣濾清器箱	1	
3	13412-SK3-00	CAP, CLEANER CASE	空氣濾清器箱蓋	1	
4	13433-SK3-00	PLATE, ELEMENT SET	濾清網固定板	1	
5	13451-SK3-00	ELEMENT, AIR CLEANER	空氣濾清網	1	
6	13453-SK2-00	JOINT, AIR CLEANER	濾清箱接頭	1	
7	13555-NAF-00	MANIFOLD, INTAKE	進氣歧管	1	
8	13610-NAF-00	REED VALVE ASSEMBLY	簧片閥總成	1	
9	13621-NAF-00	GASKET, VALVE SEAT	閥座墊片	1	
10	90210-23043	CLIP	管夾	1	
11	90260-13325	CLAMP, HOSE	軟管夾	1	
12	96510-06020-G	BOLT, SOCKET	六角承窩螺栓	4	

七、CRANKCASE 曲軸箱

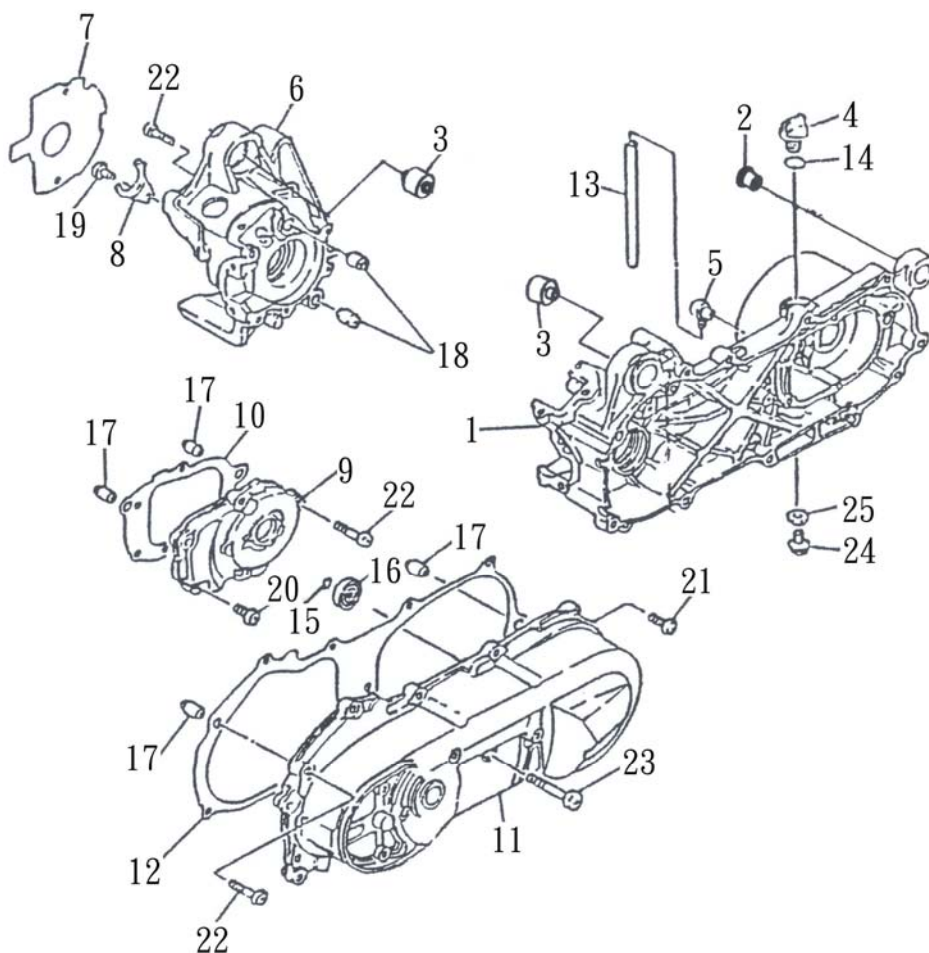

NO.	PARTS NO.	PARTS NAME	Q'TY	NOTE
項目	零件號碼	零件名稱	用量	備註
1	15111-SK5-00	CRANKCASE, LEFT	1	左曲軸箱
2	15116-SK2-01	NUT, FLANGE	1	吊板螺帽
3	15118-SK2-00	BUSH, ENGINE HANGER RUBBER	2	引擎吊架橡膠襯套
4	15163-NAF-00	PLUG, OIL	1	油標塞
5	15171-NAF-00	BREATHER	1	通風管接頭
6	15211-YAF-00	CRANKCASE, RIGHT	1	右曲軸箱
7	15221-NAF-01	GASKET, STATOR	1	電盤墊片
8	15228-NAF-00	HOLDER	1	油封固定座
9	15311-YAN-00	COVER, GEARBOX	1	變速箱蓋
10	15351-YAN-01	GASKET, GEARBOX COVER	1	變速箱蓋墊片
11	15411-SK9-00G	COVER, CRANKCASE	1	機箱蓋
12	15481-YAN-01	GASKET, CRANKCASE COVER	1	機箱蓋墊片
13	90311-50070	HOSE, BREATHER	1	透明管
14	93210-24140	O-RING	1	護油圈
15	93210-31080	O-RING	1	護油圈
16	9332K-082809ZZ	BALL BEARING (KOYO 638ZZ)	1	滾珠軸承
17	94410-10014	PIN, DOWEL	4	定位銷
18	94410-12016	PIN, DOWEL	2	定位銷
19	96310-06012-C	SCREW, PAN HEAD	1	十字孔頭螺絲
20	96310-06020-B	SCREW, PAN HEAD	3	十字孔頭螺絲
21	96310-06025-B	SCREW, PAN HEAD	8	十字孔頭螺絲
22	96310-06035-B	SCREW, PAN HEAD	10	十字孔頭螺絲

七、CRANKCASE 曲軸箱

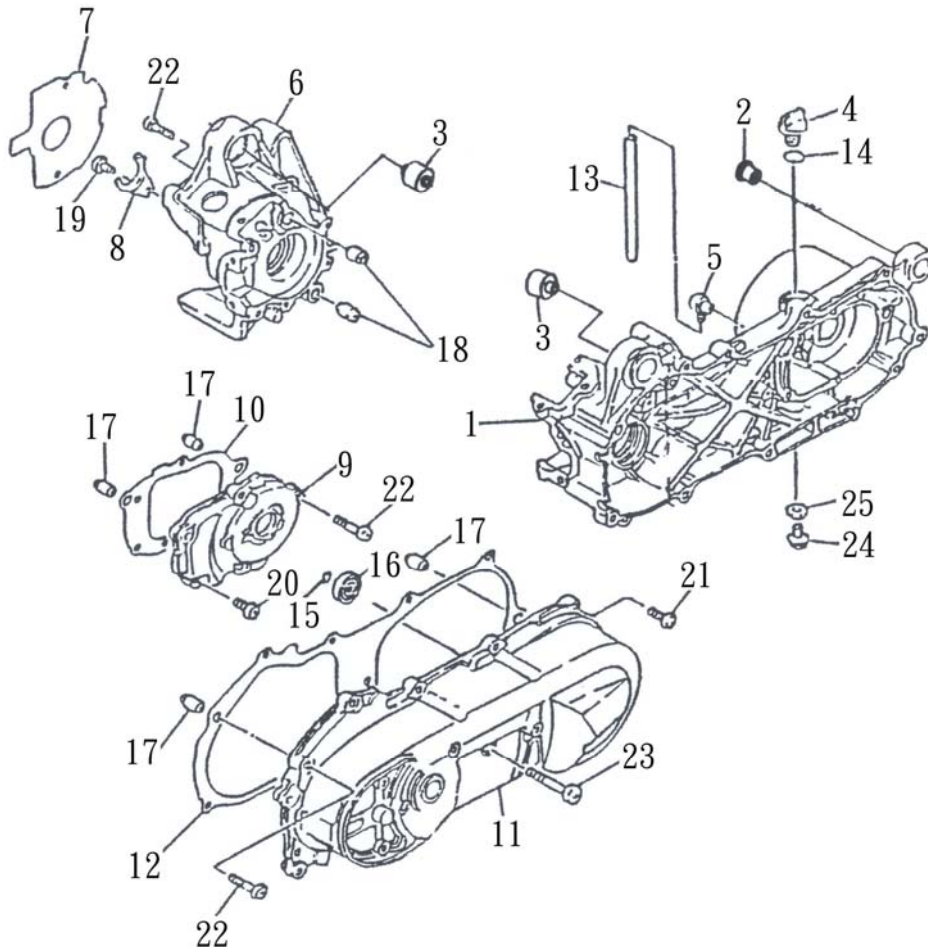

NO.	PARTS NO.	PARTS NAME	Q'TY	NOTE
項目	零件號碼	零件名稱	用量	備註
23	96310-06065-B	SCREW, PAN HEAD	1	十字孔頭螺絲
24	96414-08016-C	BOLT, FLANGE	1	凸緣螺栓
25	97230-081512	WASHER, COPPER	1	銅墊圈

八、STARTER 起動機構

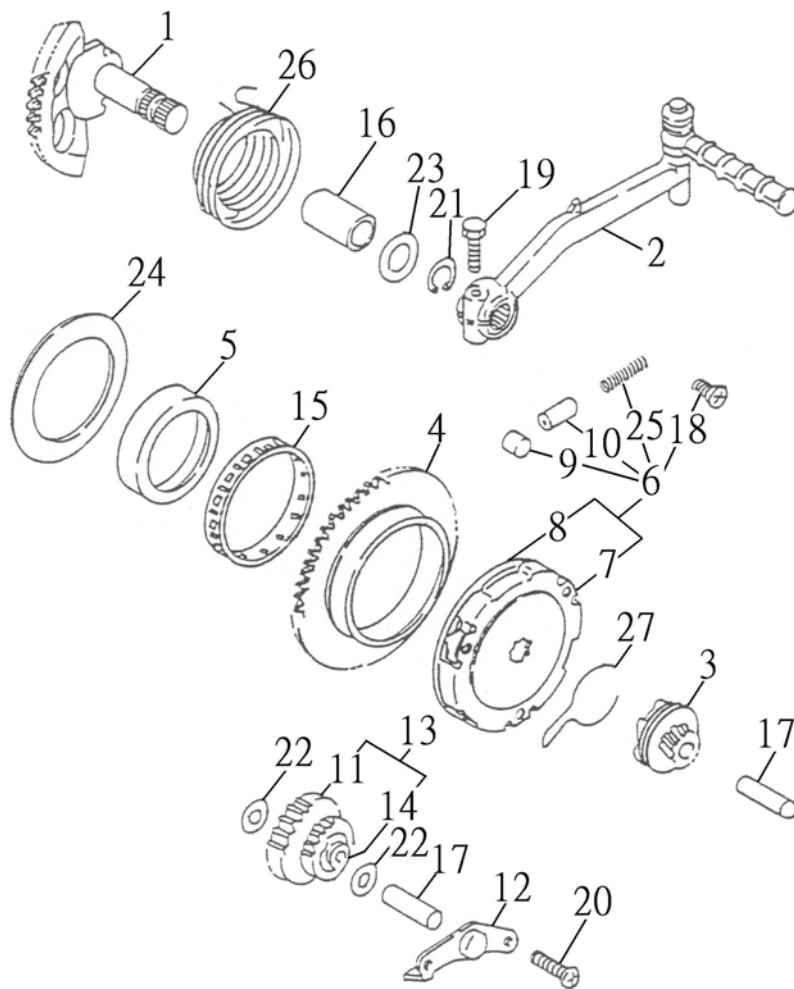

NO.	PARTS NO.	PARTS NAME	Q'TY	NOTE
項目	零件號碼	零件名稱	用量	備註
1	22601-YAN-00	KICK SHAFT ASSEMBLY	1	腳踩軸總成
2	22620-SK2-00	KICK CRANK ASSEMBLY	1	腳踩柄總成
3	22630-NAF-00	KICK PINION ASSEMBLY	1	腳踩小齒輪總成
4	23524-NAF-00	WHEEL, STARTER	1	起動輪
5	23538-NAF-00	BOSS, GEAR	1	齒輪轂
6	23570-NAF-00	STARTER CLUTCH ASSEMBLY	1	起動離合器總成
7	23572-NAF-00	STARTER CLUTCH, FIXED	1	起動離合器固定片
8	23574-NAF-00	STARTER CLUTCH, STAND	1	起動離合器塑膠座
9	23576-NAF-01	STARTER CLUTCH, ROLLER	3	起動離合器滾珠
10	23578-NAF-00	STARTER CLUTCH, COVER	3	起動離合器彈簧套
11	23612-NAF-00	IDLE GEAR	1	惰齒輪
12	23632-NAF-00	PLATE, IDLE GEAR	1	惰齒輪板
13	23650-NAF-00	IDLE GEAR ASSEMBLY	1	惰齒輪總成
14	93310-0812100	NEEDLE BEARING	1	滾針軸承
15	93310-5559127	NEEDLE BEARING	1	滾針軸承
16	93510-152030	BUSHING, KICK SHAFT	1	腳踩軸襯套
17	94510-80032	SHAFT, GEAR	2	齒輪軸
18	96104-51016-C	SCREW, TAPPING	3	自攻螺絲
19	96210-06025-K	BOLT, HEXAGON	1	六角螺栓
20	96310-06012-C	SCREW, PAN HEAD	2	十字孔頭螺絲
21	97010-15010	CIRCLIP	1	C形扣環
22	97201-081620-C	WASHER, PLATE	2	平面墊圈

八、STARTER 起動機構

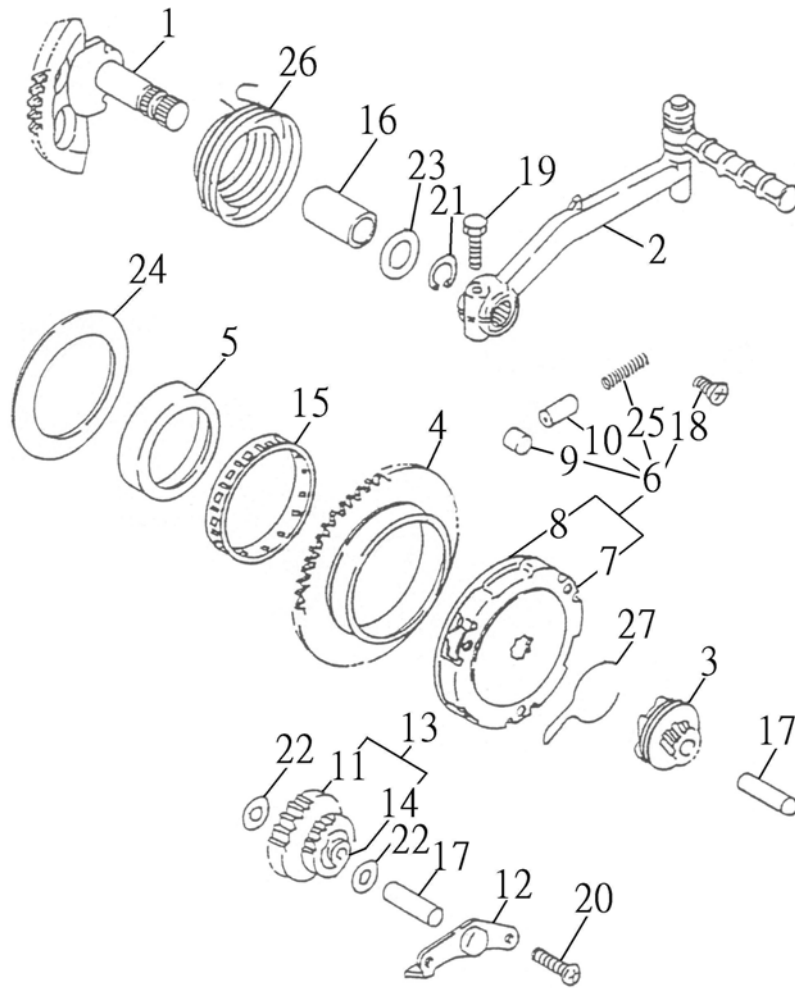

NO.	PARTS NO.	PARTS NAME	Q'TY	NOTE
項目	零件號碼	零件名稱	用量	備註
23	97201-152810-K	WASHER, PLATE	1	平面墊圈
24	97201-557606	WASHER, GASKET STARTER WHEEL	1	起動輪襯片
25	97501-02021	STARTER CLUTCH, SPRING	3	起動離合器彈簧
26	97508-32535	SPRING, TORSION	1	腳踩軸扭轉彈簧
27	97510-26300	CLIP, SPRING	1	彈簧夾

九、CLUTCH 離合器

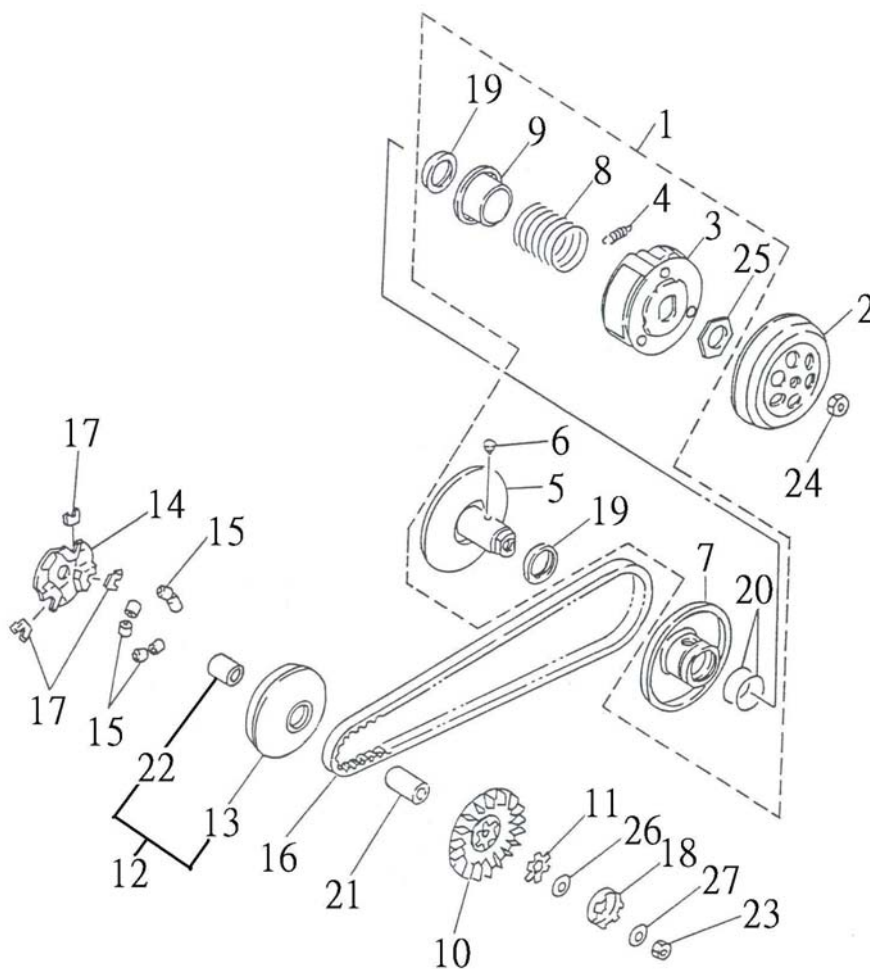

NO.	PARTS NO.	PARTS NAME		Q'TY	NOTE
項目	零件號碼	零件名稱		用量	備註
1	25602-NAF-00	SECONDARY SHEAVE ASSEMBLY	副槽輪總成	1	
2	25611-NAF-00	CLUTCH HOUSING COMP	離合器殼整體	1	
3	25620-NAF-00	CLUTCH CARRIER ASSEMBLY	離合器牽轉具總成	1	
4	25626-NAF-00	SPRING, CLUTCH WEIGHT	離合器重量彈簧	3	
5	25660-NAF-00	SECONDARY FIXED SHEAVE COMP	副固定槽輪	1	
6	25664-NAF-00	PIN, GUIDE	導銷	2	
7	25670-NAF-00	SECONDARY SLIDING SHEAVE	副滑動槽輪	1	
8	25680-NAF-00	SPRING, COMPRESSION	壓縮彈簧	1	
9	25684-NAF-00	SEAT, SECONDARY SPRING	副彈簧座	1	
10	25711-NAF-00	SHEAVE, PRIMARY FIXED	主固定槽輪	1	
11	25716-NAF-00	WASHER, CLAW	鉗墊圈	1	
12	25720-NAF-00	PRIMARY SLIDING SHEAVE COMP	主滑動槽輪整體	1	
13	25721-NAF-00	PRIMARY SLIDING SHEAVE	主滑動槽輪	1	
14	25723-NAF-00	CAM, PLATE	凸輪板	1	
15	25732-NAF-00	WEIGHT ROLLER	重錘滾子	6	
16	25741-YAF-03	V-BELT	皮帶	1	
17	25753-NAF-00	SLIDER	滑件	3	
18	25757-NAF-00	CLUTCH, ONE-WAY	單向離合器	1	
19	93110-33394	OIL SEAL KC 33*39*4	油封	2	
20	93210-20360	O-RING 36*2.0	護油圈	2	
21	93510-131838	BUSHING, SLIDING CLUTCH	主滑動槽輪襯套	1	
22	93510-182322	BUSHING, SLIDING SHEAVE	主滑動槽輪銅襯套	1	

九、CLUTCH 離合器

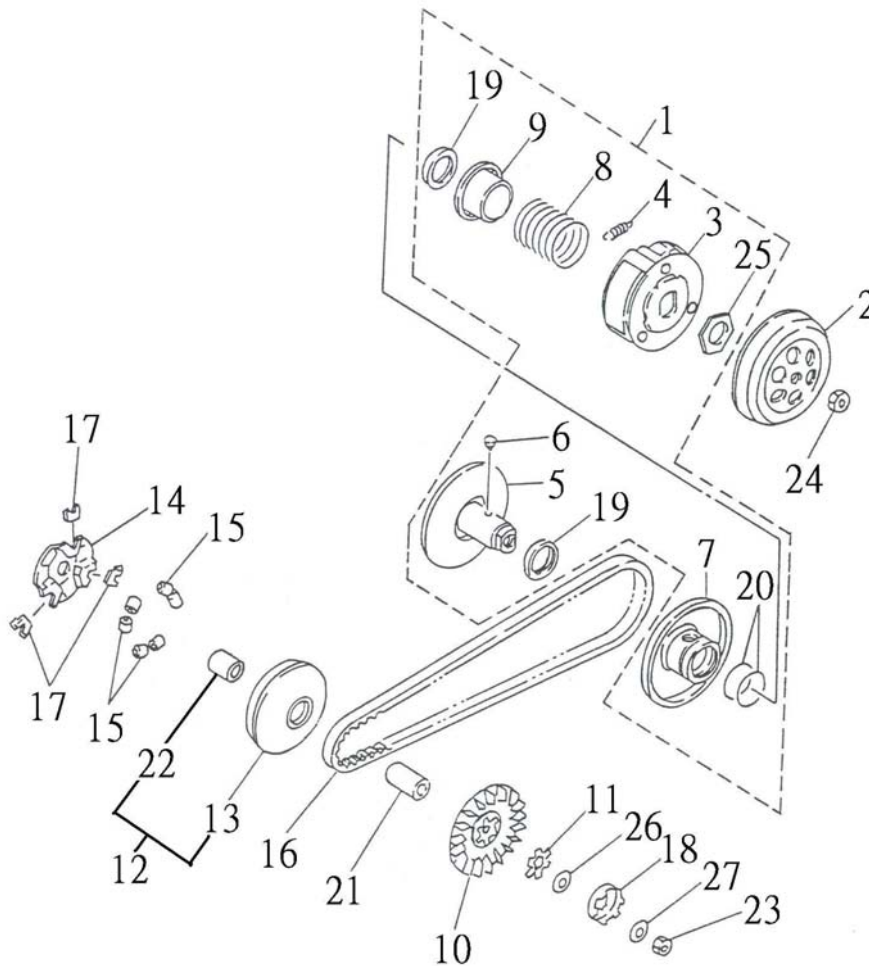

NO.	PARTS NO.	PARTS NAME	Q'TY	NOTE
項目	零件號碼	零件名稱	用量	備註
23	95201-101708-C	NUT, HEXAGON	1	六角螺帽
24	95201-102406-C	NUT, HEXAGON	1	六角螺帽
25	95201-284104-C	NUT, HEXAGON	1	六角螺帽
26	97201-131810	WASHER, PLATE	1	平面墊圈
27	97310-102425	WASHER, CONICAL SPRING	1	錐形彈簧墊圈

十、TRANSMISSION 傳動機構

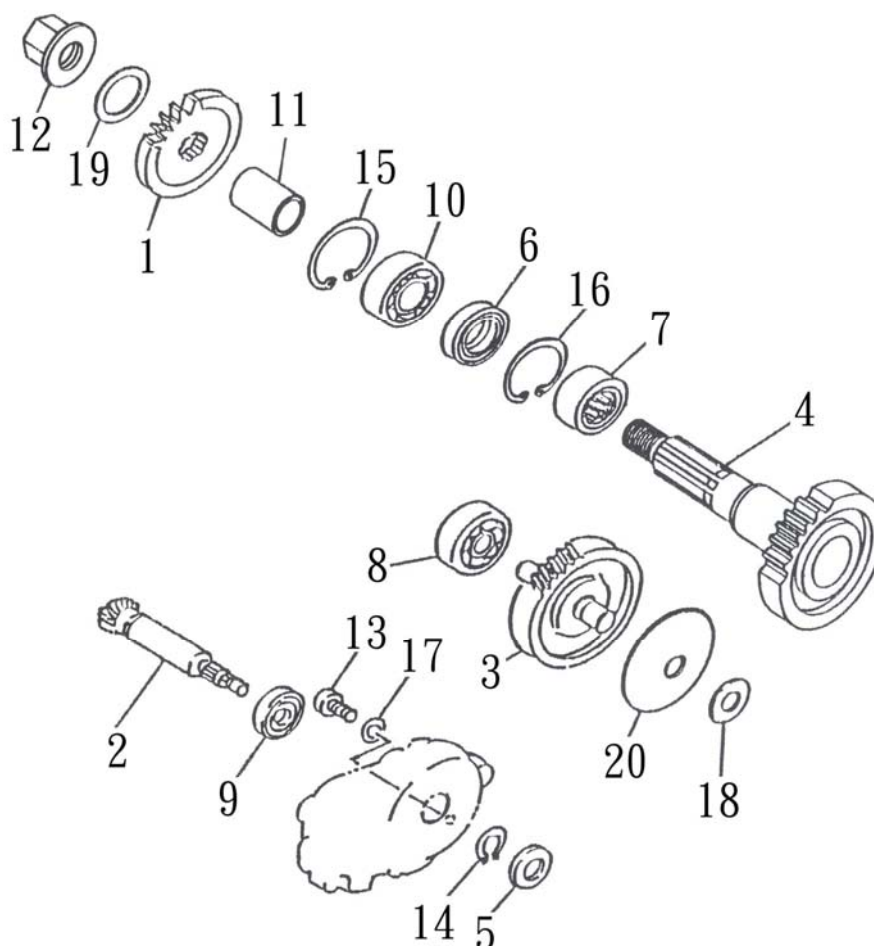

NO. 項目	PARTS NO. 零件號碼	PARTS NAME 零件名稱		Q'TY 用量	NOTE 備註
1	25711-SK2-00	SPROCKET DRIVE 415-11T	驅動鏈輪	1	
2	26111-YAF-00	GEAR, PRIMARY DRIVE 13T	主驅動軸	1	
3	26410-YAF-00	MAIN AXLE COMP 48/12T	惰輪軸總成	1	
4	26420-SK2-01	DRIVE AXLE ASSEMBLY 36T	傳動軸總成	1	
5	93110-17285	OIL SEAL 17*28*5.5	油封	1	
6	93110-25356	OIL SEAL 25*35*6	油封	1	
7	93310-2533160	NEEDLE BEARING HMK-2516	滾針軸承	1	
8	93320-123210M	BALL BEARING 6201CM/2A	滾珠軸承	1	
9	93320-173510M	BALL BEARING 6003CM/2A	滾珠軸承	1	
10	93320-204212UU	BALL BEARING 6004LLUCM/5K	滾珠軸承	1	
11	93510-202531-B	COLLAR	驅動鏈輪隔管	1	
12	95311-142214-C	NUT, NYLON	尼龍螺帽	1	
13	96310-06010-B	SCREW, PAN HEAD	十字孔頭螺栓	1	
14	97010-17010-K	CIRCLIP STW-17	C形扣環	1	
15	97012-42018-K	CIRCLIP RTW-42	C形內扣環	1	
16	97013-33012-K	CIRCLIP IR-33	C形內扣環	1	
17	97201-061910-B	WASHER, PLATE	平面墊圈	1	
18	97201-122210	WASHER, PLATE	平面墊圈	1	
19	97201-152930-B	WASHER, PLATE	平面墊圈	1	
20	97310-126005	WASHER, CONICAL SPRING	錐形彈簧墊圈	1	

十一、GENERATOR 發電機

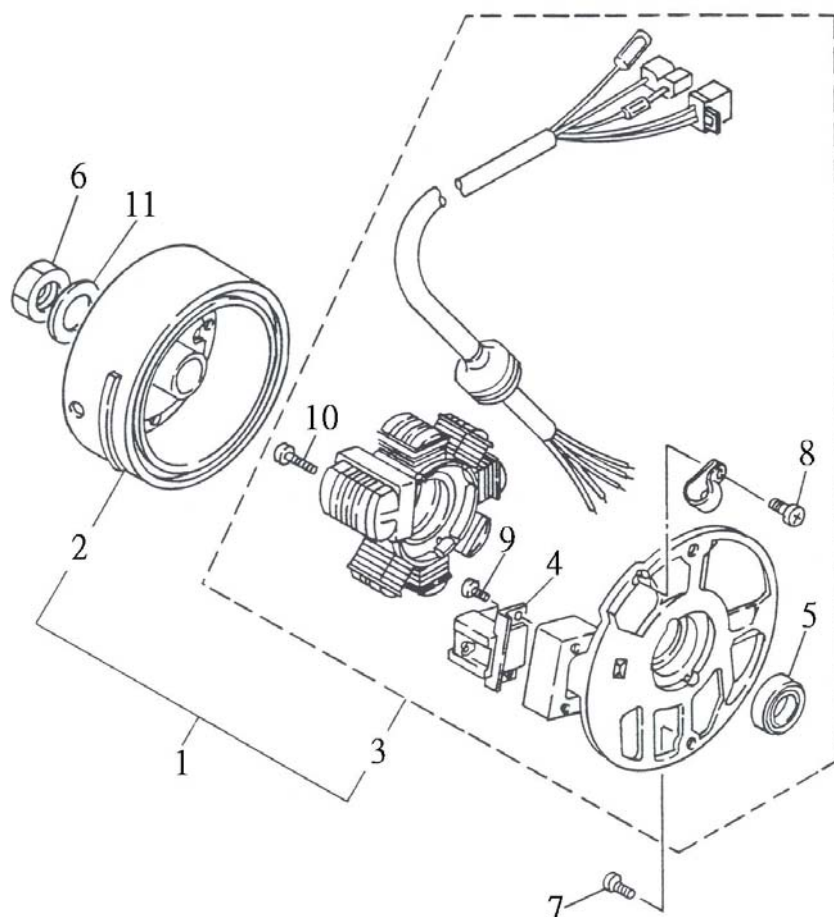

NO. 項目	PARTS NO. 零件號碼	PARTS NAME 零件名稱	Q'TY 用量	NOTE 備註
1	35500-NAF-00	GENERATOR ASSEMBLY	1	發電機總成
2	35550-NAF-00	ROTOR ASSEMBLY	1	轉子總成
3	35560-NAF-00	BASE ASSEMBLY	1	發電機座總成
4	35580-NAF-00	COIL, PULSE	1	脈動線圈
5	93110-19265	OIL SEAL	1	油封
6	95201-101408-C	NUT, HEXAGON	1	六角螺帽
7	96310-06016-C	SCREW, PAN HEAD	2	十字孔頭螺絲
8	96312-04008-C	SCREW, PAN HEAD WITH WASHER	1	十字孔頭螺絲附墊圈
9	96312-06010-C	SCREW, PAN HEAD WITH WASHER	2	十字孔頭螺絲附墊圈
10	96312-06025-C	SCREW, PAN HEAD WITH WASHER	2	十字孔頭螺絲附墊圈
11	97201-101726-C	WASHER, PLATE	1	平面墊圈

十二、STARTING MOTOR 起動馬達

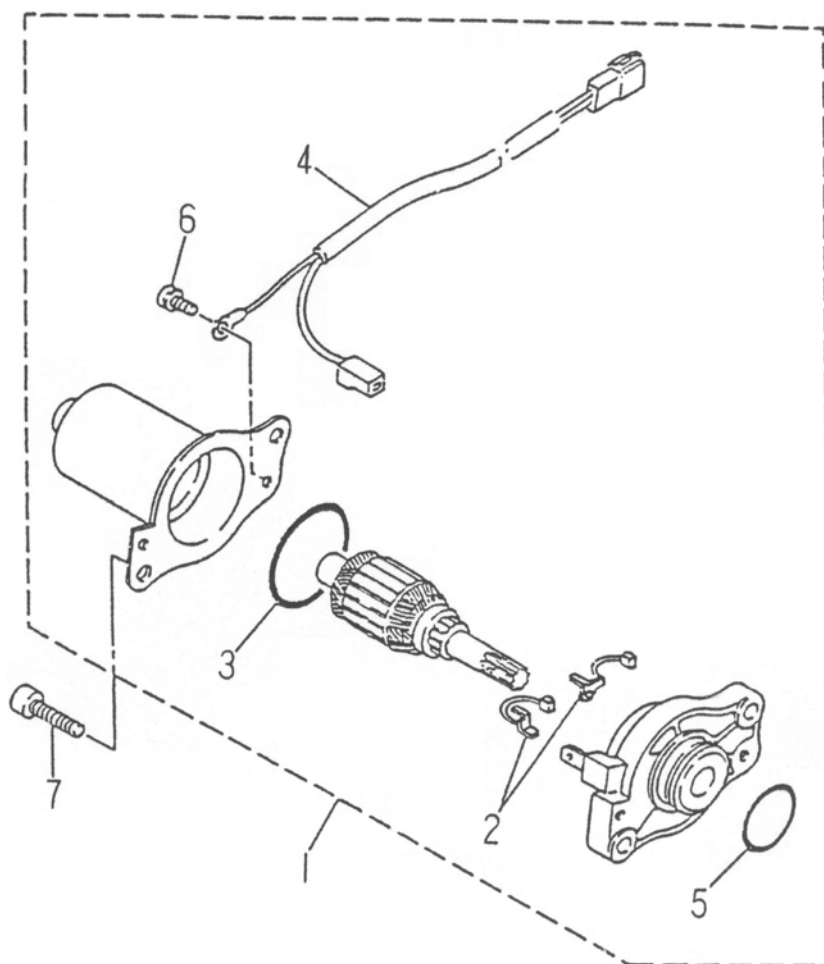

NO.	PARTS NO.	PARTS NAME		Q'TY	NOTE
項目	零件號碼	零件名稱		用量	備註
1	35800-NAF-00	STARTING MOTOR ASSEMBLY	起動馬達	1	
2	35801-NAF-00	BRUSH SET	電刷組	1	
3	35811-NAF-00	GASKET, YOKE	墊片	1	
4	35831-NAF-00	CORD COMP	線圈總成	1	
5	93210-19230	O-RING	護油圈	1	
6	96312-04012-C	SCREW, PAN HEAD WITH WASHER	十字孔頭螺絲附墊圈	2	
7	96510-06020-G	BOLT, SOCKET	六角承窩螺栓	2	

十三、EXHAUST MUFFLER 排氣管

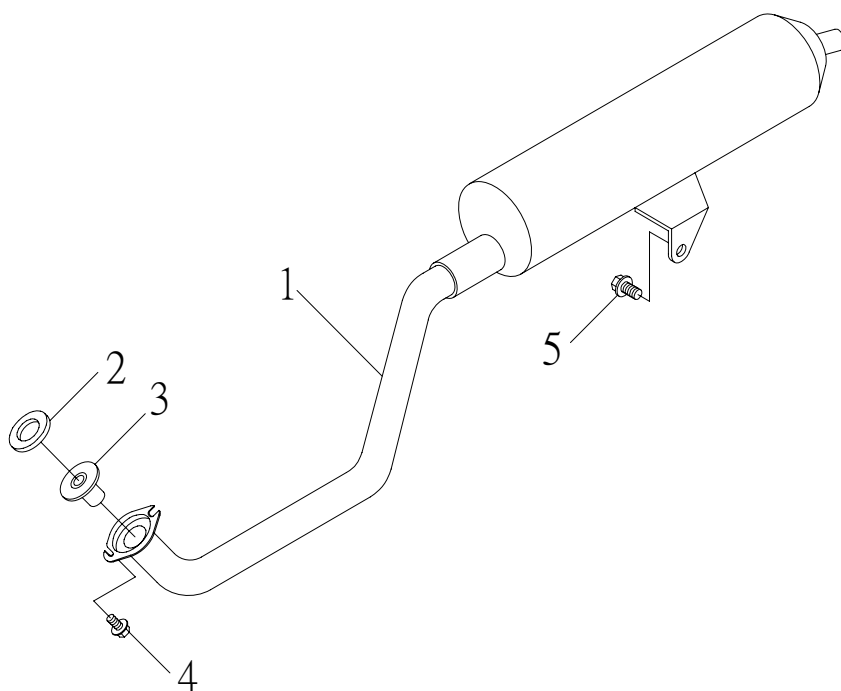

NO.	PARTS NO.	PARTS NAME		Q'TY	NOTE
項目	零件號碼	零件名稱		用量	備註
1	31610-SK2-00	EXHAUST MUFFLER ASS'Y	排氣管總成	1	
2	31613-NAF-00	GASKET, EXHAUST PIPE (25.4*34*4)	排氣管墊片	1	
3	31615-NAF-02	PIPE, REDUCTION (Ø9)	減速管	1	
4	94714-06018-C	BOLT, FLANGE	十字孔頭凸緣螺絲	2	
5	96414-08016-B	BOLT, FLANGE	凸緣螺栓	1	

十四、REAR SUSPENSION 後懸吊系統

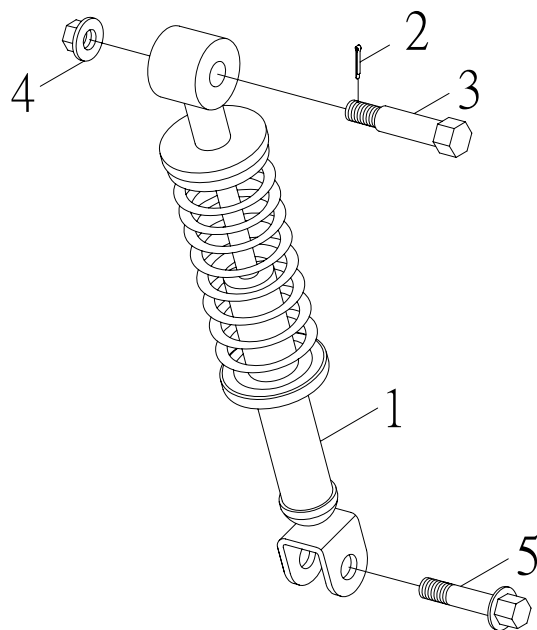

NO.	PARTS NO.	PARTS NAME		Q'TY	NOTE
項目	零件號碼	零件名稱		用量	備註
1	32210-SK2-00	SHOCK ABSORBER ASS'Y, REAR	後緩衝器總成	1	
2	90240-18016-B	COTTER PIN 1.8*16	開口銷	1	
3	94716-08039-B	BOLT	後緩衝器固定軸	1	
4	95401-081208-B	NUT, FLANGE	凸緣螺帽	1	
5	96414-08035-B	BOLT, FLANGE	凸緣螺栓	1	

十五、REAR BRAKE 後剎車系統

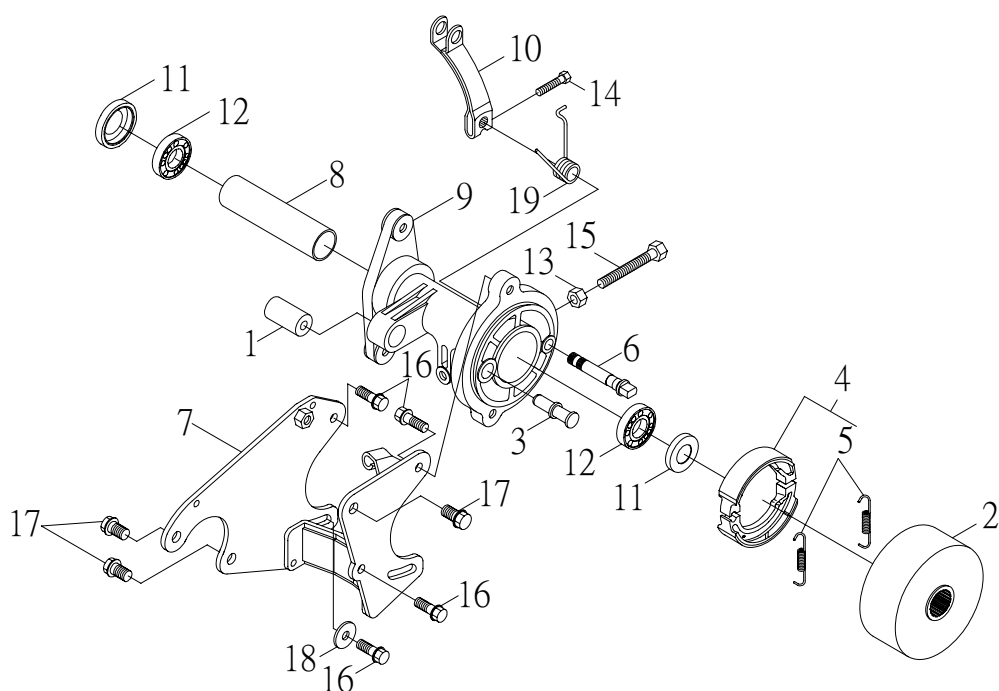

NO. 項目	PARTS NO. 零件號碼	PARTS NAME 零件名稱		Q'TY 用量	NOTE 備註
1	15116-NAF-00	BUSH, REAR SHOCK ABSORBER	後緩衝器襯套	1	
2	32320-SK2-00	HUB, REAR BRAKE	後剎車轂	1	
3	32326-SK2-00	PIN, PIVOT	後剎車固定軸	1	
4	32345-SK2-00	BRAKE SHOE KIT	後剎車塊組	1	
5	32346-SK2-00	SPRING, TENSION	後剎車拉伸彈簧	2	
6	32351-SK2-00	CAMSHAFT	後剎車凸輪軸	1	
7	41191-SK2-00	ENGINE HANGER	引擎後固定座	1	
8	42815-SK2-00	SPACER, BEARING	後輪隔管	1	
9	42881-SK2-00	HUB, REAR	後輪轂	1	
10	45855-SK9-00	LEVER, CAMSHAFT	前剎車搖臂	1	
11	93110-30477	OIL SEAL 30*47*7	油封	2	
12	9332C-254712	BALL BEARING 6005CO	滾珠軸承	2	
13	95201-081207-B	NUT, HEXAGON	六角螺帽	1	
14	96210-05025-B	BOLT, HEXAGON	六角螺栓	1	
15	96210-08055-B	BOLT, HEXAGON	六角螺栓	1	
16	96414-08016-B	BOLT, FLANGE	凸緣螺栓	5	
17	96414-10020-B	BOLT, FLANGE	凸緣螺栓	3	
18	97201-082420-B	WASHER, PLATE 8.7*24*2.0	平面墊圈	2	
19	97508-25155-B	SPRING TORSION	後剎車扭轉彈簧	1	

十六、FRAME 車架

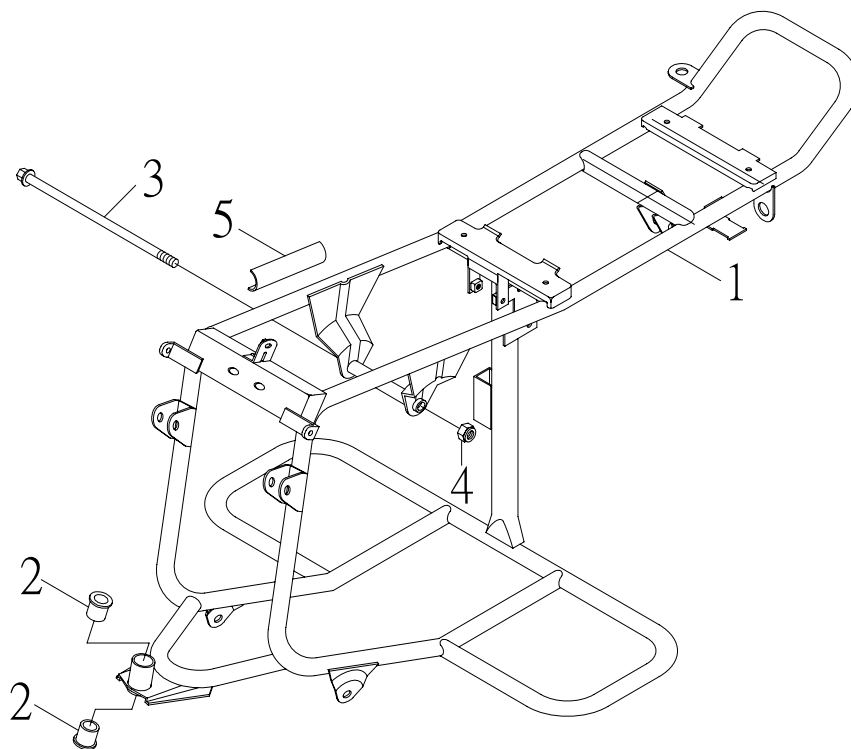

NO.	PARTS NO.	PARTS NAME	Q'TY	NOTE
項目	零件號碼	零件名稱	用量	備註
1	41110-SK2-01	FRAME COMP	1	車架整體
2	93330-152118	BUSH, SOLID	2	羅龍滑動軸承
3	94610-10190-B	BOLT, FLANGE	1	吊架固定軸
4	95311-101710-B	NUT, NYLON	1	尼龍螺帽
5	62111-CHP-00	PADDED	2	蓄電池襯墊

十七、STEERING 轉向裝置

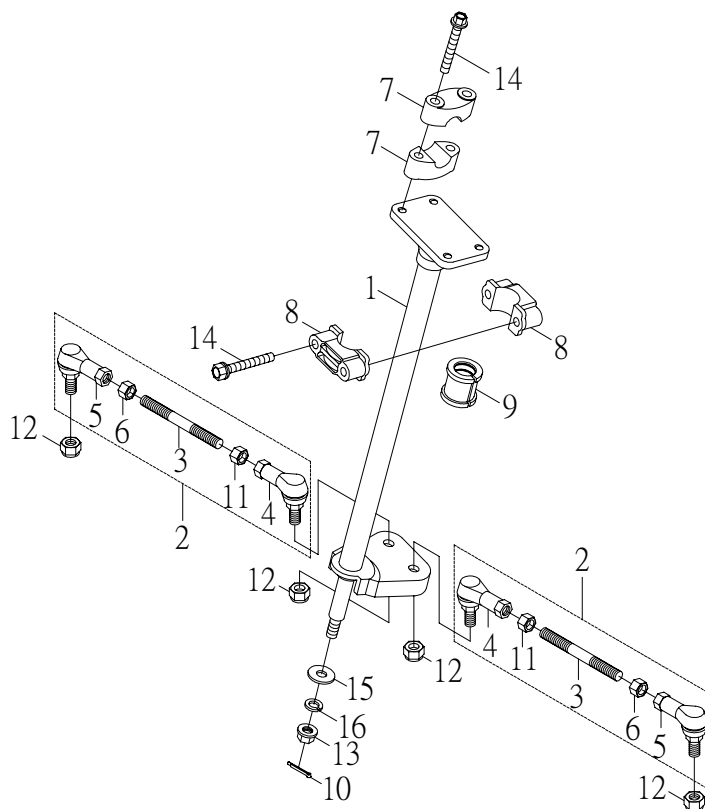

NO.	PARTS NO.	PARTS NAME	Q'TY	NOTE
項目	零件號碼	零件名稱	用量	備註
1	42101-SK2-00	COLUMN, STEERING	1	轉向桿
2	42140-SK2-00	ROD, TIE ASS'Y	2	連桿總成
3	42141-SK2-00	ROD, TIE	2	連桿
4	42142-SK2-00	JOINT, UNIVERSAL R	2	萬向接頭 右
5	42143-SK2-00	JOINT, UNIVERSAL L	2	萬向接頭 左
6	42146-SK2-00	NUT	2	連桿螺帽
7	46125-SK2-00	HOLDER, HANDLE UPPER	4	把手上固定座
8	46411-SK2-00	BEARING, STEERING	2	轉向桿固定座
9	46417-SK2-00	PU BUSH	1	PU襯套
10	90240-23020-B	COTTER PIN 2.3*20	1	開口銷
11	95201-101408-B	NUT, HEXAGON	2	六角螺帽
12	95311-101710-B	NUT, NYLON	4	尼龍螺帽
13	95401-101409-B	NUT, FLANGE	1	凸緣螺帽
14	96414-08050-B	BOLT, FLANGE	6	凸緣螺栓
15	97201-102620-B	WASHER, PLATE	1	平面墊圈
16	97301-101720-B	WASHER, SPRING	1	彈簧墊圈

十八、FRONT SUSPENSION 前懸吊系統

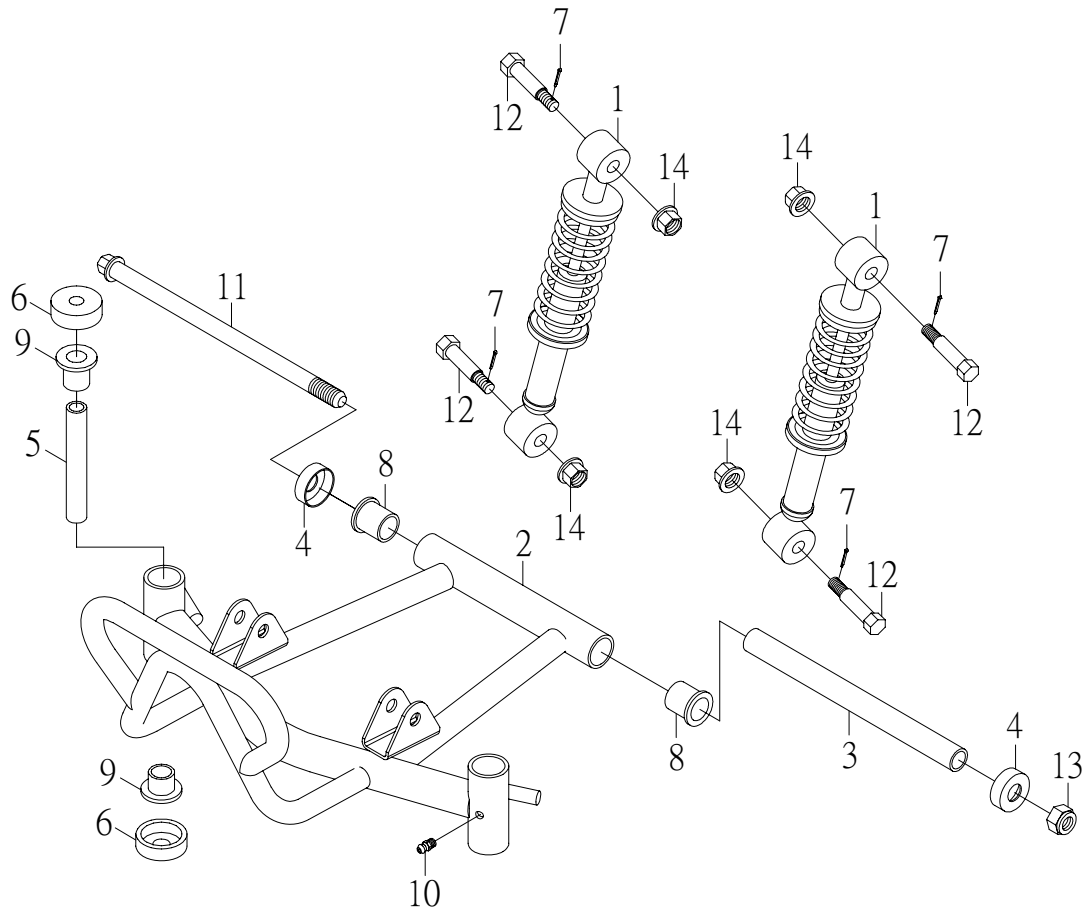

NO. 項目	PARTS NO. 零件號碼	PARTS NAME 零件名稱	Q'TY 用量	NOTE 備註
1	42126-SK2-00	SHOCK ABSORBER ASS'Y	2	前緩衝器總成
2	42161-SK2-01	FRT, ARM	1	前搖臂
3	42173-RAM-00	COLLAR	1	搖臂軸襯
4	42183-RAM-00	COVER, THRUST	2	塵封蓋
5	45825-SK9-00	COLLAR	2	轉向關節座軸襯
6	45827-SK9-00	COVER, THRUST	4	塵封蓋
7	90240-18016-B	PIN COTTER 1.8*16	4	開口銷
8	93330-152118	BUSH, SOLID	2	羅龍滑動軸承
9	93330-172330	BUSH, SOLID	4	羅龍滑動軸承
10	94340-06010-B	NIPPLE, GREASE	2	黃油嘴
11	94610-10200-C	BLOT, FLANGE	1	前輪軸
12	94716-08039-B	BLOT	4	後緩衝器固定軸
13	95311-101710-B	NUT, NYLON	1	尼龍螺帽
14	95401-081208-B	NUT, FLANGE	4	凸緣螺帽

十九、FRONT WHEEL 前輪

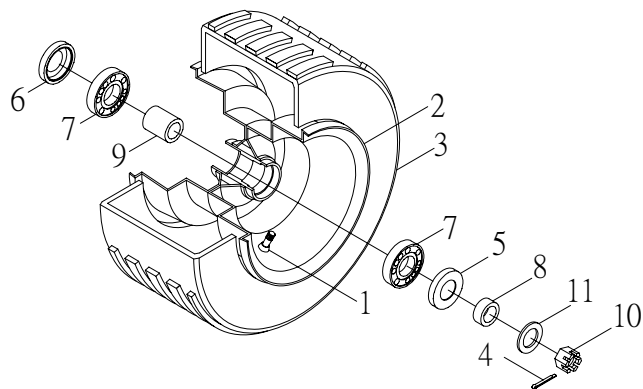

NO.	PARTS NO.	PARTS NAME		Q'TY	NOTE
項目	零件號碼	零件名稱		用量	備註
1	42570-RAM-00	VALVE, RIM	氣門嘴	2	
2	42580-SK2-00	WHEEL, FRONT	前輪圈	2	
3	42590-SK2-00	TIRE, FRONT 145/70-6	輪胎	2	
4	90240-29025-B	COTTER PIN 2.9*25	開口銷	2	
5	93110-20355	OIL SEAL 20*35*5	油封	2	
6	93110-22357	OIL SEAL 22*35*7	油封	2	
7	9332C-153511	BALL BEARING 6202 CO	滾珠軸承	4	
8	93510-152008-B	COLLAR	前輪殼側隔管	2	
9	93510-152233-B	SPACER, BEARING	前輪間隔管	2	
10	95321-142215-C	NUT, CASTLE	有槽螺帽	2	
11	97201-142620-C	WASHER, PLATE 14.7*25.7*2	平面墊圈	2	

二十、REAR WHEEL 後輪

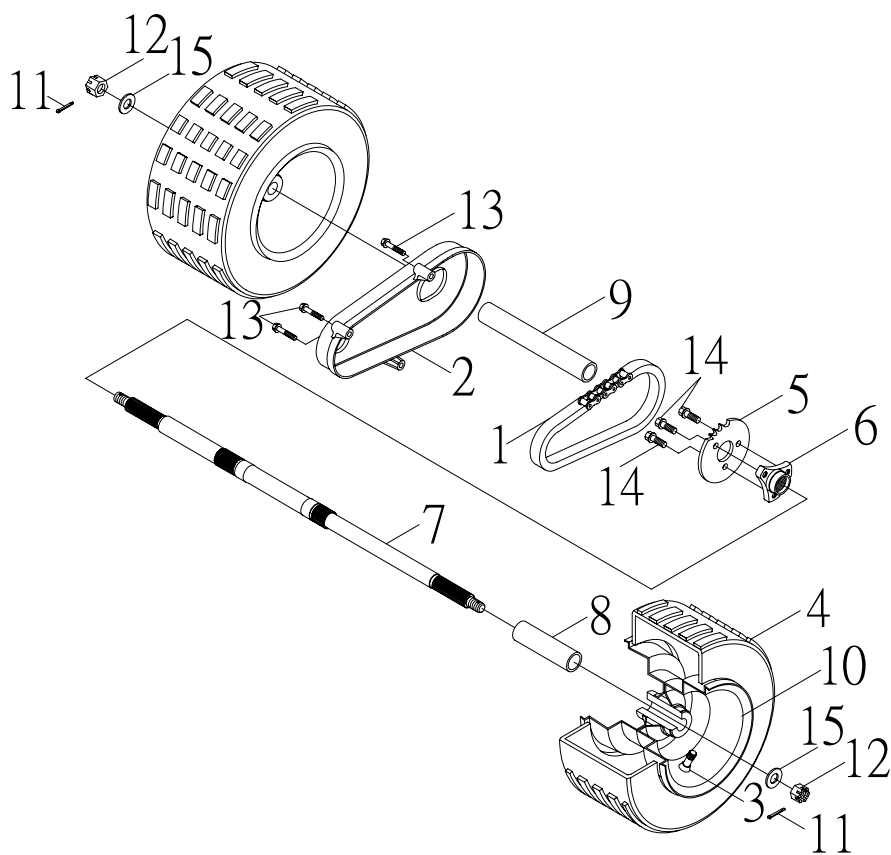

NO.	PARTS NO.	PARTS NAME	Q'TY	NOTE
項目	零件號碼	零件名稱	用量	備註
1	25741-SK2-00	CHAIN 415H*40L	1	鏈條
2	32191-SK2-00	DRIVE CHAIN CASE	1	鏈條蓋
3	42570-RAM-00	VALVE, RIM	2	氣門嘴
4	42590-SK2-00	TIRE, FRONT 145/70-6	2	輪胎
5	42812-SK2-00	SPROCKET, DRIVEN 415-21T	1	傳動鏈輪
6	42821-SK2-00	DRIVE SPROCKET BASE	1	傳動鏈輪座
7	42835-SK2-00	AXLE, WHEEL	1	後輪軸
8	42836-SK2-00	SPACER, BEARING L	1	後輪左隔管
9	42837-SK2-00	SPACER, BEARING R	1	後輪右隔管
10	42880-SK2-00	TIRE, REAR	2	後輪圈
11	90240-29025-B	COTTER PIN 2.9*25	2	開口銷
12	95321-142215-C	NUT, CASTLE	2	有槽螺帽
13	96414-06022-B	BOLT, FLANGE	3	凸緣螺栓
14	96414-08012-B	BOLT, FLANGE	3	凸緣螺栓
15	97201-142620-C	WASHER, PLATE 14.7*25.7*2	2	平面墊圈

二十一、FUEL TANK 油箱

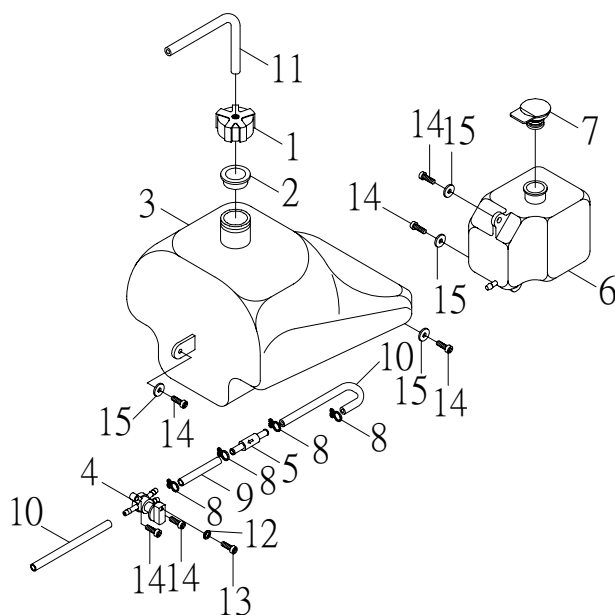

NO.	PARTS NO.	PARTS NAME	Q'TY	NOTE
項目	零件號碼	零件名稱	用量	備註
1	43102-SK2-00	CAP ASS'Y	1	汽油箱蓋
2	43103-SK2-00	CAP WASHER	1	油箱蓋封圈
3	43110-SK2-00	PETROL TANK	1	汽油箱
4	43500-SK3-00	FUEL COCK ASS'Y	1	油杯
5	43570-NAF-00	LEACH	1	過濾杯
6	43751-SK2-00	OIL TANK	1	潤滑油箱
7	43771-NAF-01	BODY, CAP	1	潤滑油箱蓋
8	90210-12010	CLIP	4	管夾
9	90310-50075	HOSE, FUEL 5*10*75	1	汽油管
10	90310-50150	HOSE, FUEL 5*10*150	2	汽油管
11	90310-50440	HOSE 5*8*440	1	通氣管
12	93210-15020	O-RING	1	護油圈
13	94712-04014-K	SCREW, FLAT HEAD	1	十字孔埋頭螺絲
14	96310-06016-C	SCREW, PAN HEAD	6	十字孔頭螺絲
15	97201-061820-B	WASHER, PLATE	4	平面墊圈

二十二、STEERING KNUCKLE 轉向關節座

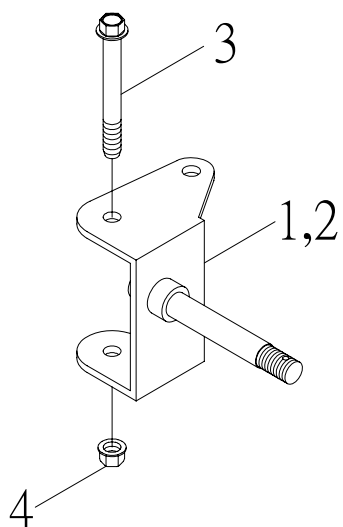

NO.	PARTS NO.	PARTS NAME		Q'TY	NOTE
項目	零件號碼	零件名稱		用量	備註
1	45861-SK2-00	KNUCKLE, STEERING L	左前轉向關節座	1	
2	45866-SK2-00	KNUCKLE, STEERING R	右前轉向關節座	1	
3	94610-10103-B	BOLT, FLANGE	轉向關節固定軸	2	
4	95311-101710-B	NUT, NYLON	尼龍螺帽	2	

二十三、STEERING HANDLE CABLE 轉向把手,鋼索

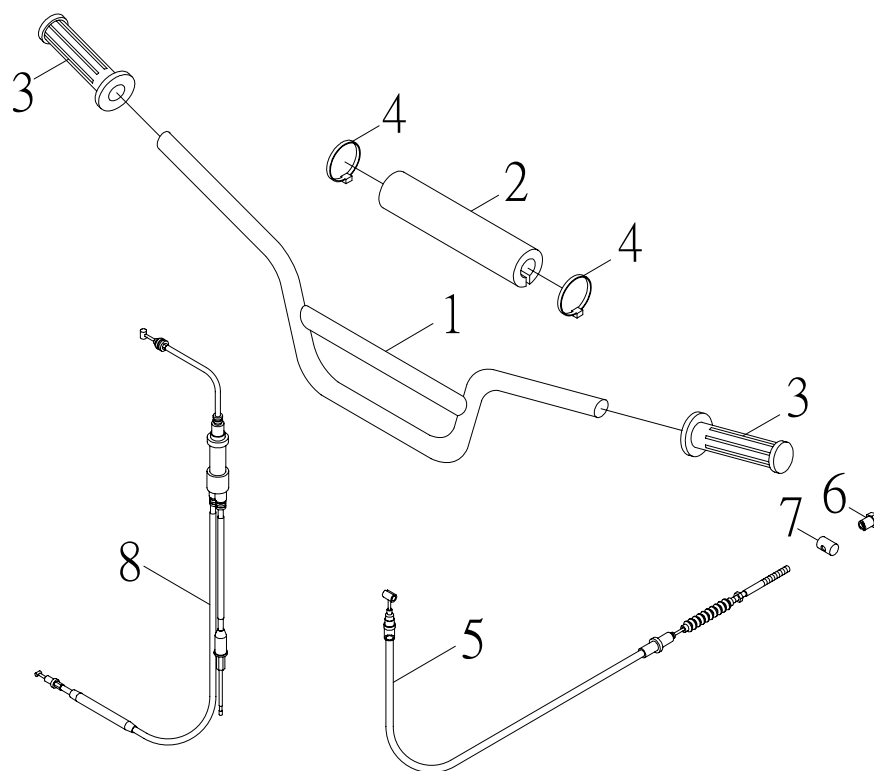

NO.	PARTS NO.	PARTS NAME	Q'TY	NOTE
項目	零件號碼	零件名稱	用量	備註
1	46110-SK2-00	HANDLEBAR	1	把手整體
2	46117-SK2-00	PROTECTOR	1	把手橫桿護套
3	46240-SK2-00	GRIP	2	握把
4	61135-SK2-00	BAND, CORD 100mm	2	束帶
5	61320-SK2-00	CABLE, BRAKE	1	後剎車鋼索
6	61379-NAF-01	NUT, ADJUST	1	調整螺帽
7	61389-NAF-00	PIN, FIXTURE	1	導線固定塊
8	61620-SK2-00	CABLE, THROTTLE	1	節流鋼索

二十四、FRONT FENDER, WARNING 前土除、警告標示

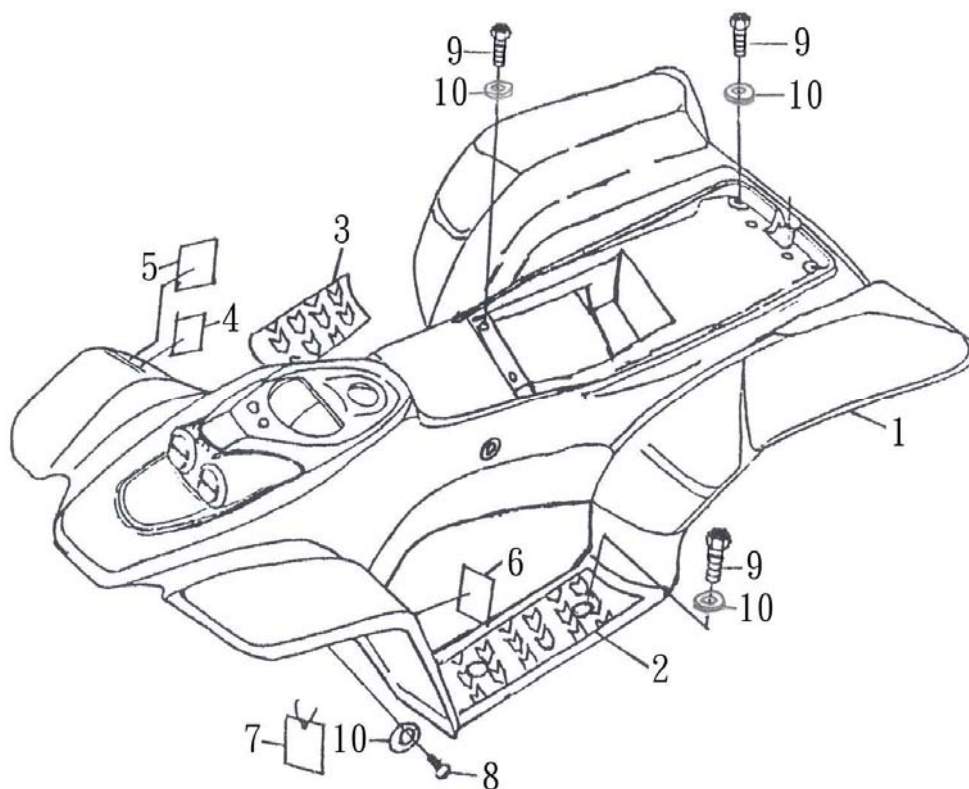

NO.	PARTS NO.	PARTS NAME		Q'TY	NOTE
項目	零件號碼	零件名稱		用量	備註
1	51171-SK3-00	SIDE COVER	側蓋	1	
2	53483-SK2-00	MAT L	左踏板墊	1	
3	53484-SK2-00	MAT R	右踏板墊	1	
4	56576-SK2-00	LABEL WARNING 3 (Tire)	胎壓規範	1	
5	56578-SK2-00	LABEL WARNING 2 (Age)	年齡規範	1	
6	56781-SK2-00	LABEL WARNING 1 (Operation)	騎乘規範	1	
7	56782-RAM-00	ATV WARN.TAG SPORT	娛樂規範 (吊卡)	1	
8	96318-06012-G	SCREW, PAN HEAD	十字孔頭螺絲	2	
9	96318-06015-G	SCREW, PAN HEAD	十字孔頭螺絲	8	
10	97321-061825-G	WASHER, FLANGE	凸緣墊圈	10	

二十五、SEAT 座墊

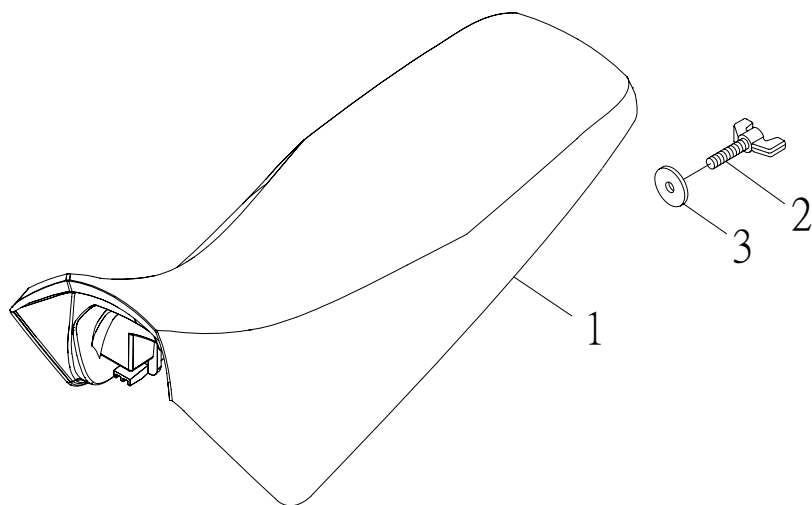

NO.	PARTS NO.	PARTS NAME		Q'TY	NOTE
項目	零件號碼	零件名稱		用量	備註
1	52730-SK2-00	SINGLE SEAT ASS'Y (BLACK)	單人座墊總成	1	
	52730-SK2-0009	SINGLE SEAT ASS'Y (ORANGE)	單人座墊總成	1	
2	94716-06016-C	BOLT, BUTTERFLY	蝶形螺栓	1	
3	97201-062220-B	WASHER, PLATE	平面墊圈	1	

二十六、HEADLIGHT 前燈

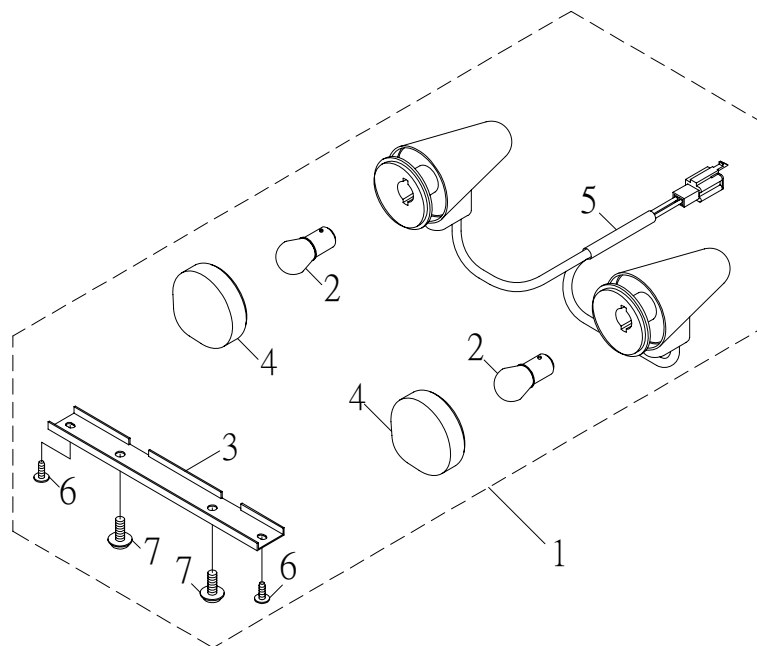

NO.	PARTS NO.	PARTS NAME	Q'TY	NOTE
項目	零件號碼	零件名稱	用量	備註
1	55300-SK3-00	HEAD LIGHT ASS'Y	1	前燈總成
2	55314-SK3-00	BULB, HEAD LIGHT 12V8W	2	前燈燈泡
3	55315-SK3-00	STAY, HEAD LIGHT	1	前燈固定座
4	55320-SK3-00	LENS ASS'Y	2	前燈單元總成
5	55340-SK3-00	SOCKET CORD ASS'Y	1	燈座總成
6	96112-41218-K	SCREW, TAPPING	2	自攻螺絲
7	96318-06012-G	SCREW, PAN HEAD	2	十字孔頭螺絲

二十七、WIRE HARNESS 主電路配線

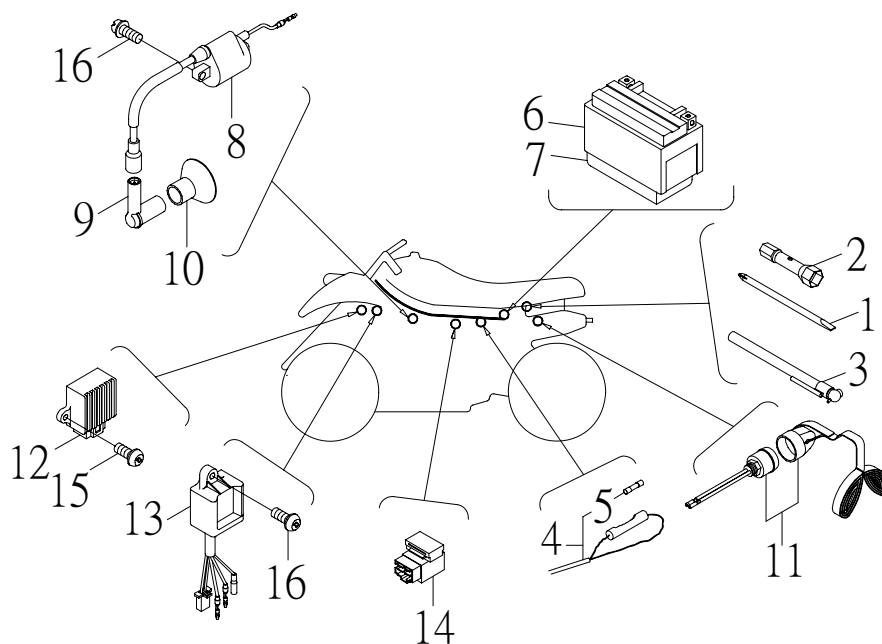

NO. 項目	PARTS NO. 零件號碼	PARTS NAME 零件名稱	Q'TY 用量	NOTE 備註
1	56120-NAF-00	SCREW DRIVER	1	螺栓起子
2	56140-SK9-00	TOOL PLUG	1	火星塞工具
3	56190-RAM-00	GAUGE, AIR	1	胎壓計
4	61120-SK3-00	WIRE, HARNESS	1	主配線總成
5	61151-NAF-00	FUSE	1	保險絲
6	62100-NAF-00	BATTERY ASS'Y (YTX4L-BS)	1	蓄電池總成
	62100-NAF-01	BATTERY ASS'Y	1	蓄電池總成
7	62111-SK9-00	BATTERY PACKING	1	蓄電池襯墊
8	62310-NAF-00	IGNITION COIL ASS'Y	1	點火線圈總成
9	62320-NAF-00	PLUG CAP ASS'Y	1	火星塞蓋總成
10	62322-NAF-00	SEAL, PLUG CAP	1	火星塞蓋套
11	62330-SK9-00	ENGINE STOP SWITCH ASS'Y	1	安全開關總成
12	62360-NAF-00	RECTIFIER & REGULATOR COMP	1	整流穩壓器
13	62540-NAF-00	C.D.I UNIT ASS'Y	1	C.D.I 組件總成
14	62550-SK2-00	STARTER RELAY SWITCH COMP	1	起動開關組
15	96310-05012-B	SCREW, PAN HEAD 5*12	2	十字孔頭螺絲
16	96312-06020-C	SCREW, PAN HEAD WITH WASHER	2	十字孔頭螺絲附墊圈

二十八、REMOTE CONTROL ENGINE STOP SWITCH 遙控器組

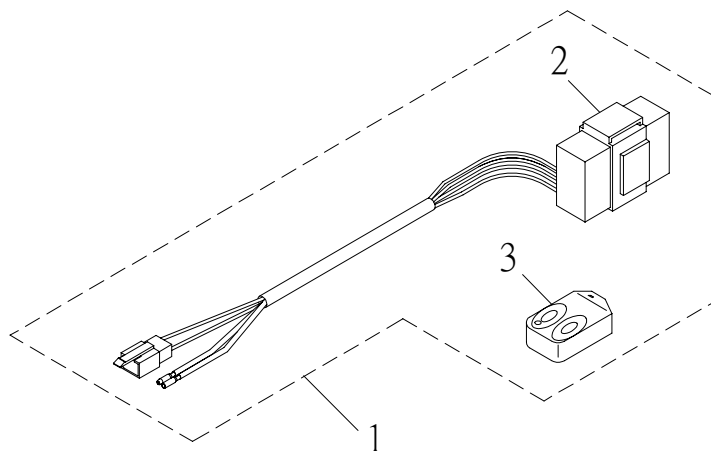

NO.	PARTS NO.	PARTS NAME		Q'TY	NOTE
項目	零件號碼	零件名稱		用量	備註
1	62330-SK2-01	REMOTE CONTROL ASS'Y	遙控器組	1	
2	62331-SK2-01	RECEPTION INSTRUMENT	接收器	1	
3	62332-SK2-01	REMOTE CONTROL	遙控器	1	

二十九、HANDLE SWITCH, LEVER 把手開關、拉桿

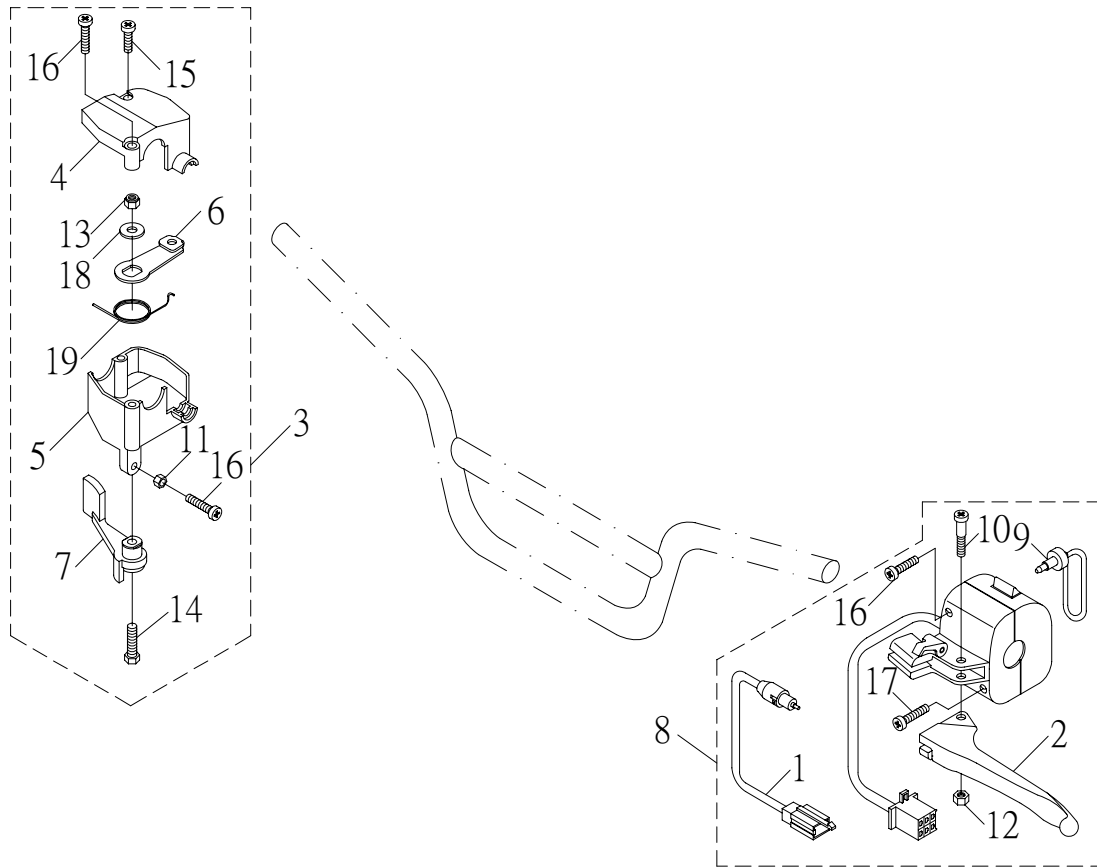

NO.	PARTS NO.	PARTS NAME	Q'TY	NOTE
項目	零件號碼	零件名稱	用量	備註
1	45890-SK9-00	FRONT STOP SWITCH	1	前剎車燈開關
2	62912-SK2-00	LEVER, L	1	左拉桿
3	62920-SK2-00	THROTTLE LEVER ASS'Y	1	節流拉桿座總成
4	62923-SK2-00	CAP, THROTTLE	1	節流閥蓋
5	62925-SK2-00	THROTTLE LEVER	1	節流拉桿座
6	62927-SK2-00	ARM, THROTTLE	1	節流搖臂
7	62928-SK2-00	LEVER, THROTTLE	1	節流推桿
8	62930-SK2-00	HANDLE SWITCH ASS'Y L	1	左把手開關總成
9	62935-SK2-00	ENGINE STOP BELT	1	安全束帶
10	94710-05023-G	BOLT, LEVER	1	拉桿螺栓
11	95201-050804-G	NUT, HEXAGON	1	六角螺帽
12	95311-050805-G	NUT, NYLON	1	尼龍螺帽
13	95311-061006-G	NUT, NYLON	1	尼龍螺帽
14	96210-06020-B	BOLT, HEXAGON	1	六角螺栓
15	96310-05015-G	SCREW, PAN HEAD	1	十字孔頭螺絲
16	96310-05020-G	SCREW, PAN HEAD	3	十字孔頭螺絲
17	96310-05025-G	SCREW, PAN HEAD	1	十字孔頭螺絲
18	97201-061616-C	WASHER, PLATE 6.5*16*1.6	1	平面墊圈
19	97508-10240-B	SPRING	1	節流閥扭轉彈簧